

**ERVING/GILL
ROUTE 2**

STATE	FED. AID PROJ. NO.	SHEET NO.	TOTAL SHEETS
MA	NHP(IM)-003S(265)X	8	27
PROJECT FILE NO.		612088	

TRAFFIC SIGN AND MARKINGS SKETCH

CONTINUED ON
SHEET NO 9

N / F
COMMONWEALTH OF MASSACHUSETTS DPW
(NO REF)

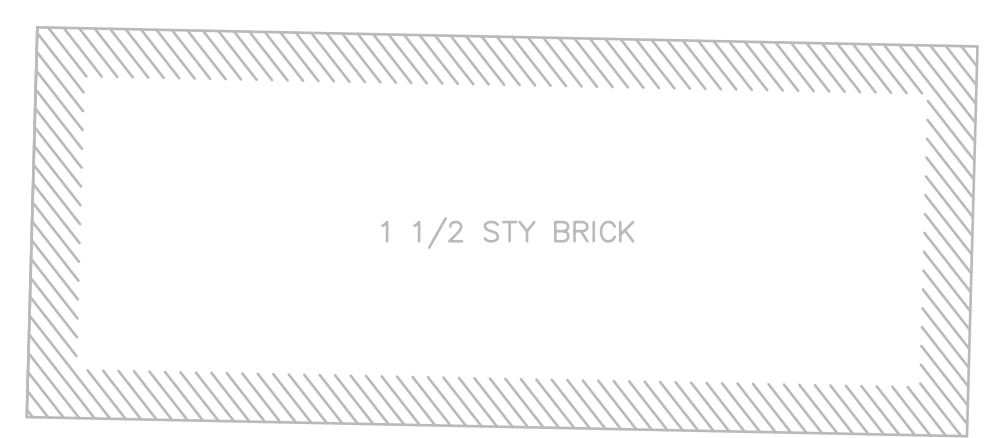

PROP R3-17
PROP R3-17aP

SWALE

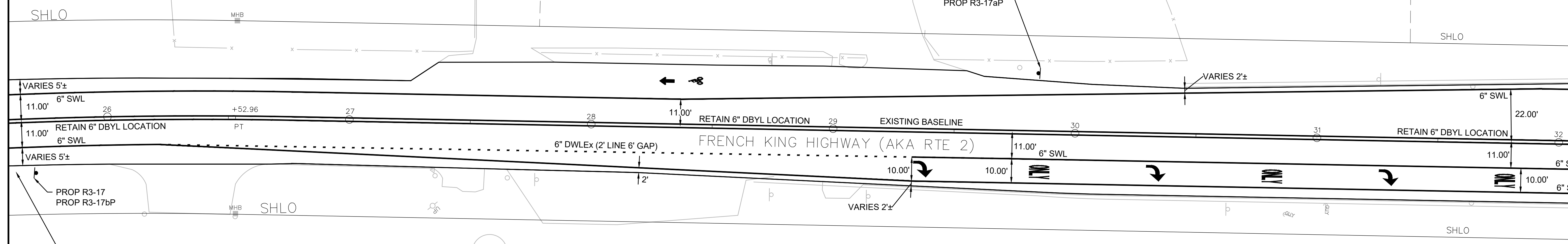

SEE TYPICALS SECTIONS FOR PAVEMENT
MARKINGS BEYOND THIS STATION

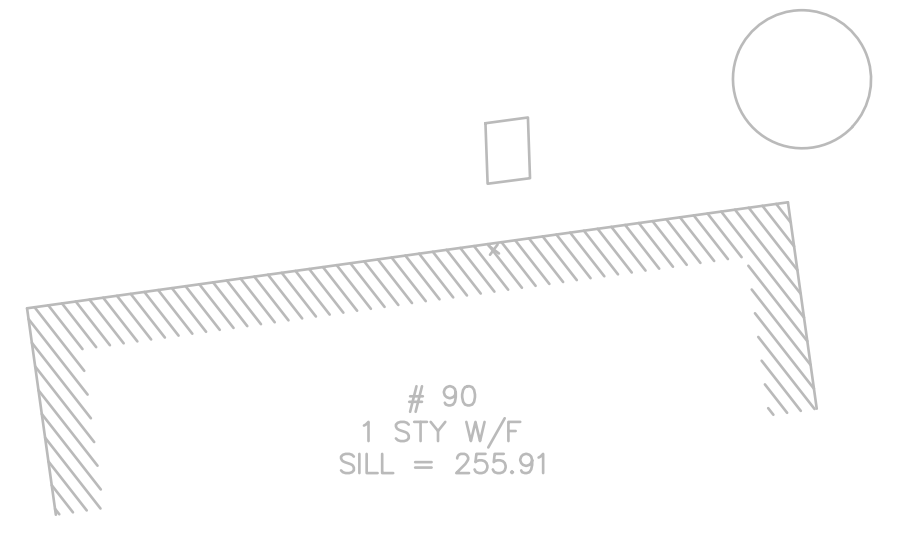

N / F
HELEN CARROLL
BOOK 1140 / PAGE 200

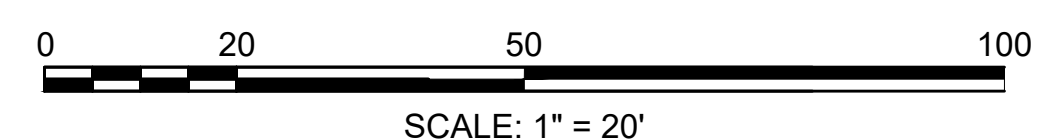

- NOTES:**
- THIS IS A SKETCH PLAN ONLY. THE EXISTING LOCATION OF THE DOUBLE YELLOW CENTER LINE SHALL BE RETAINED AS NOTED ON THE PLAN. THE OTHER ADJACENT DOUBLE YELLOW LINE AT PAINTED ISLAND LOCATIONS AND ALL OTHER PAVEMENT MARKINGS SHALL BE OFFSET FROM THE RETAINED DOUBLE YELLOW LINE TO DIMENSIONS SHOWN ON THIS PLAN.
 - THE CONTRACTOR IS RESPONSIBLE FOR REFERENCING AND RECORDING ALL EXISTING PAVEMENT MARKINGS, THEIR LOCATIONS AND DIMENSIONS. THE LENGTHS OF TURNING LANES, BYPASS LANES, EXISTING PAINTED ISLANDS, PASSING ZONES AND NO PASSING ZONES SHALL BE RETAINED.
 - EXISTING BASELINE SHOWN FOR INFORMATION ONLY.
 - UNLESS OTHERWISE NOTED, ALL SIGNS SHOWN OR NOT SHOWN ON MARKINGS SKETCH SHALL BE RETAINED.

ERVING/GILL
ROUTE 2

STATE	FED. AID PROJ. NO.	SHEET NO.	TOTAL SHEETS
MA	NHP(IM)-003S(265)X	9	27
PROJECT FILE NO.		612088	

TRAFFIC SIGN AND MARKINGS SKETCH

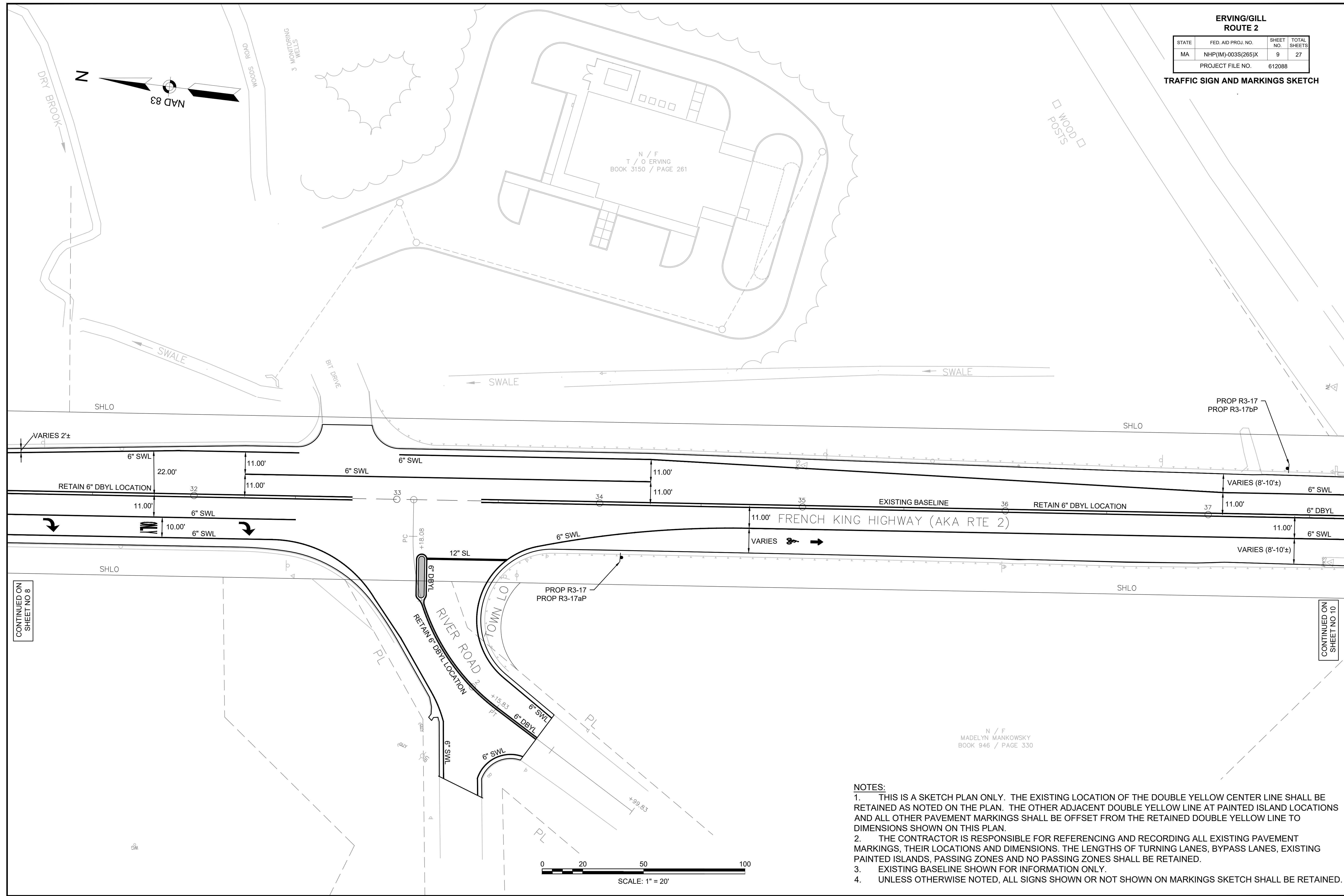

CONTINUED ON
SHEET NO 8

CONTINUED ON
SHEET NO 10

N / F
MADELYN MANKOWSKY
BOOK 946 / PAGE 330

- NOTES:**
1. THIS IS A SKETCH PLAN ONLY. THE EXISTING LOCATION OF THE DOUBLE YELLOW CENTER LINE SHALL BE RETAINED AS NOTED ON THE PLAN. THE OTHER ADJACENT DOUBLE YELLOW LINE AT PAINTED ISLAND LOCATIONS AND ALL OTHER PAVEMENT MARKINGS SHALL BE OFFSET FROM THE RETAINED DOUBLE YELLOW LINE TO DIMENSIONS SHOWN ON THIS PLAN.
 2. THE CONTRACTOR IS RESPONSIBLE FOR REFERENCING AND RECORDING ALL EXISTING PAVEMENT MARKINGS, THEIR LOCATIONS AND DIMENSIONS. THE LENGTHS OF TURNING LANES, BYPASS LANES, EXISTING PAINTED ISLANDS, PASSING ZONES AND NO PASSING ZONES SHALL BE RETAINED.
 3. EXISTING BASELINE SHOWN FOR INFORMATION ONLY.
 4. UNLESS OTHERWISE NOTED, ALL SIGNS SHOWN OR NOT SHOWN ON MARKINGS SKETCH SHALL BE RETAINED.

ERVING/GILL
ROUTE 2

STATE	FED. AID PROJ. NO.	SHEET NO.	TOTAL SHEETS
MA	NHP(IM)-003S(265)X	10	27
PROJECT FILE NO.		612088	

TRAFFIC SIGN AND MARKINGS SKETCH

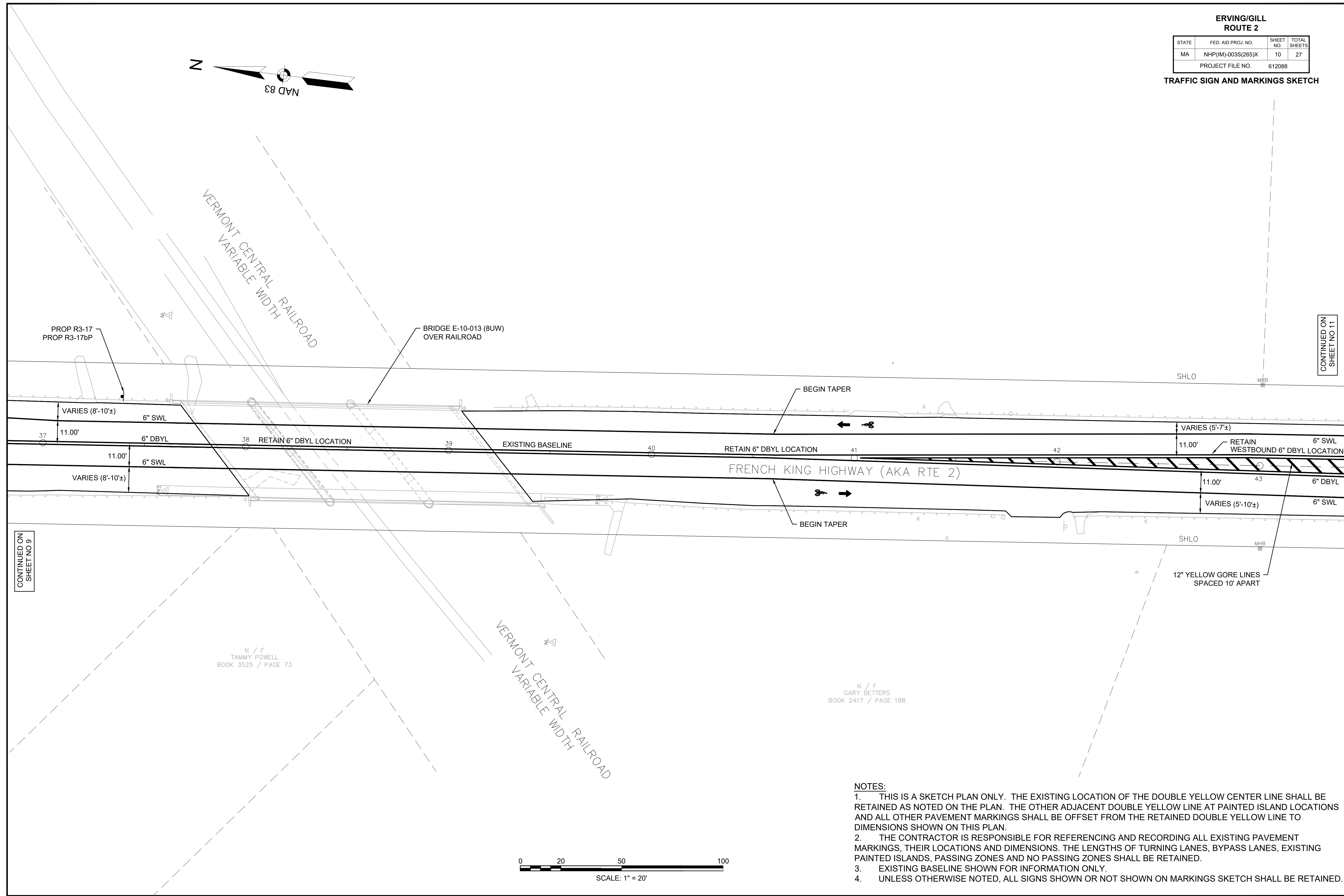
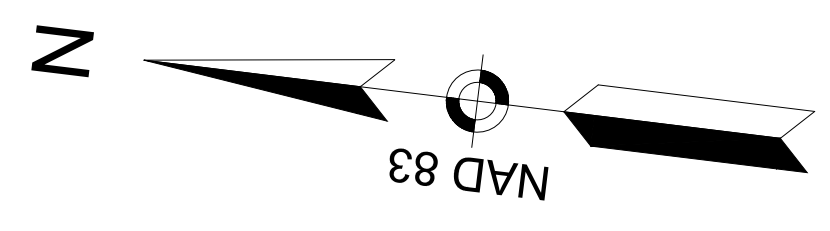

CONTINUED ON SHEET NO 9

CONTINUED ON SHEET NO 11

N / F
TAMMY POWELL
BOOK 3525 / PAGE 73

N / F
GARY BETTERS
BOOK 2417 / PAGE 188

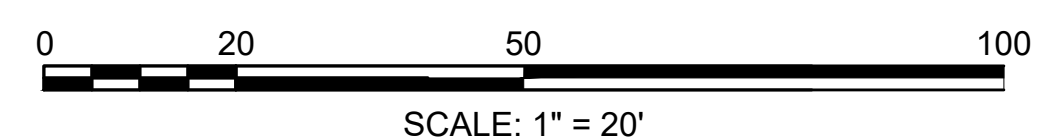

- NOTES:**
- THIS IS A SKETCH PLAN ONLY. THE EXISTING LOCATION OF THE DOUBLE YELLOW CENTER LINE SHALL BE RETAINED AS NOTED ON THE PLAN. THE OTHER ADJACENT DOUBLE YELLOW LINE AT PAINTED ISLAND LOCATIONS AND ALL OTHER PAVEMENT MARKINGS SHALL BE OFFSET FROM THE RETAINED DOUBLE YELLOW LINE TO DIMENSIONS SHOWN ON THIS PLAN.
 - THE CONTRACTOR IS RESPONSIBLE FOR REFERENCING AND RECORDING ALL EXISTING PAVEMENT MARKINGS, THEIR LOCATIONS AND DIMENSIONS. THE LENGTHS OF TURNING LANES, BYPASS LANES, EXISTING PAINTED ISLANDS, PASSING ZONES AND NO PASSING ZONES SHALL BE RETAINED.
 - EXISTING BASELINE SHOWN FOR INFORMATION ONLY.
 - UNLESS OTHERWISE NOTED, ALL SIGNS SHOWN OR NOT SHOWN ON MARKINGS SKETCH SHALL BE RETAINED.

ERVING/GILL
ROUTE 2

STATE	FED. AID PROJ. NO.	SHEET NO.	TOTAL SHEETS
MA	NHP(1M)-003S(265)X	11	27
PROJECT FILE NO.		612088	

TRAFFIC SIGN AND MARKINGS SKETCH

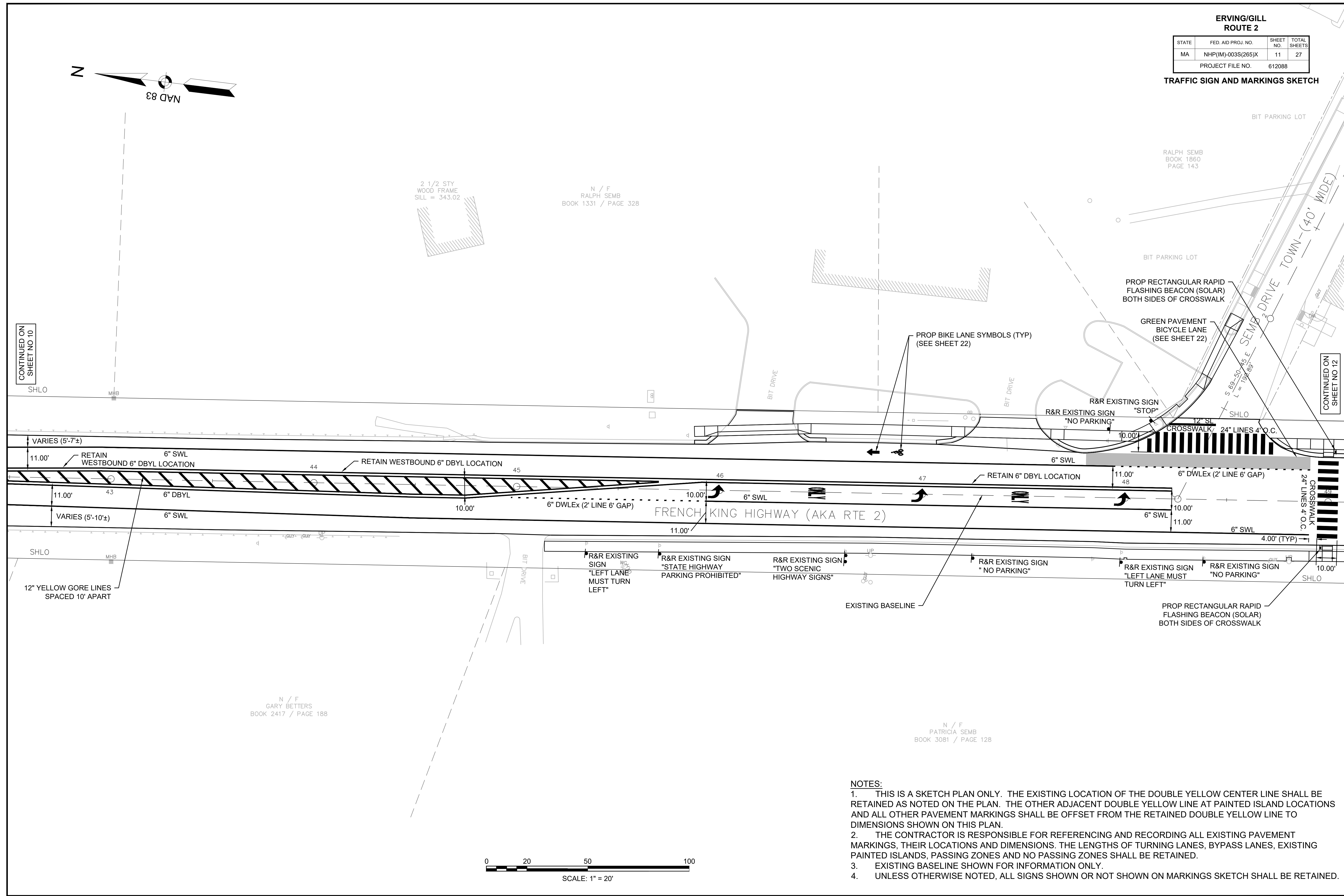
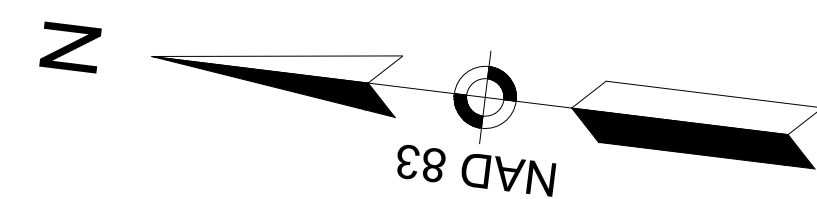

CONTINUED ON SHEET NO 10

CONTINUED ON SHEET NO 12

N / F
GARY BETTERS
BOOK 2417 / PAGE 188

N / F
PATRICIA SEMB
BOOK 3081 / PAGE 128

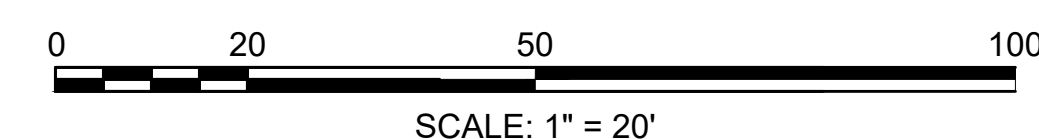

- NOTES:**
1. THIS IS A SKETCH PLAN ONLY. THE EXISTING LOCATION OF THE DOUBLE YELLOW CENTER LINE SHALL BE RETAINED AS NOTED ON THE PLAN. THE OTHER ADJACENT DOUBLE YELLOW LINE AT PAINTED ISLAND LOCATIONS AND ALL OTHER PAVEMENT MARKINGS SHALL BE OFFSET FROM THE RETAINED DOUBLE YELLOW LINE TO DIMENSIONS SHOWN ON THIS PLAN.
 2. THE CONTRACTOR IS RESPONSIBLE FOR REFERENCING AND RECORDING ALL EXISTING PAVEMENT MARKINGS, THEIR LOCATIONS AND DIMENSIONS. THE LENGTHS OF TURNING LANES, BYPASS LANES, EXISTING PAINTED ISLANDS, PASSING ZONES AND NO PASSING ZONES SHALL BE RETAINED.
 3. EXISTING BASELINE SHOWN FOR INFORMATION ONLY.
 4. UNLESS OTHERWISE NOTED, ALL SIGNS SHOWN OR NOT SHOWN ON MARKINGS SKETCH SHALL BE RETAINED.

ERVING/GILL
ROUTE 2

STATE	FED. AID PROJ. NO.	SHEET NO.	TOTAL SHEETS
MA	NHP(IM)-003S(265)X	12	27
PROJECT FILE NO.		612088	

TRAFFIC SIGN AND MARKINGS SKETCH

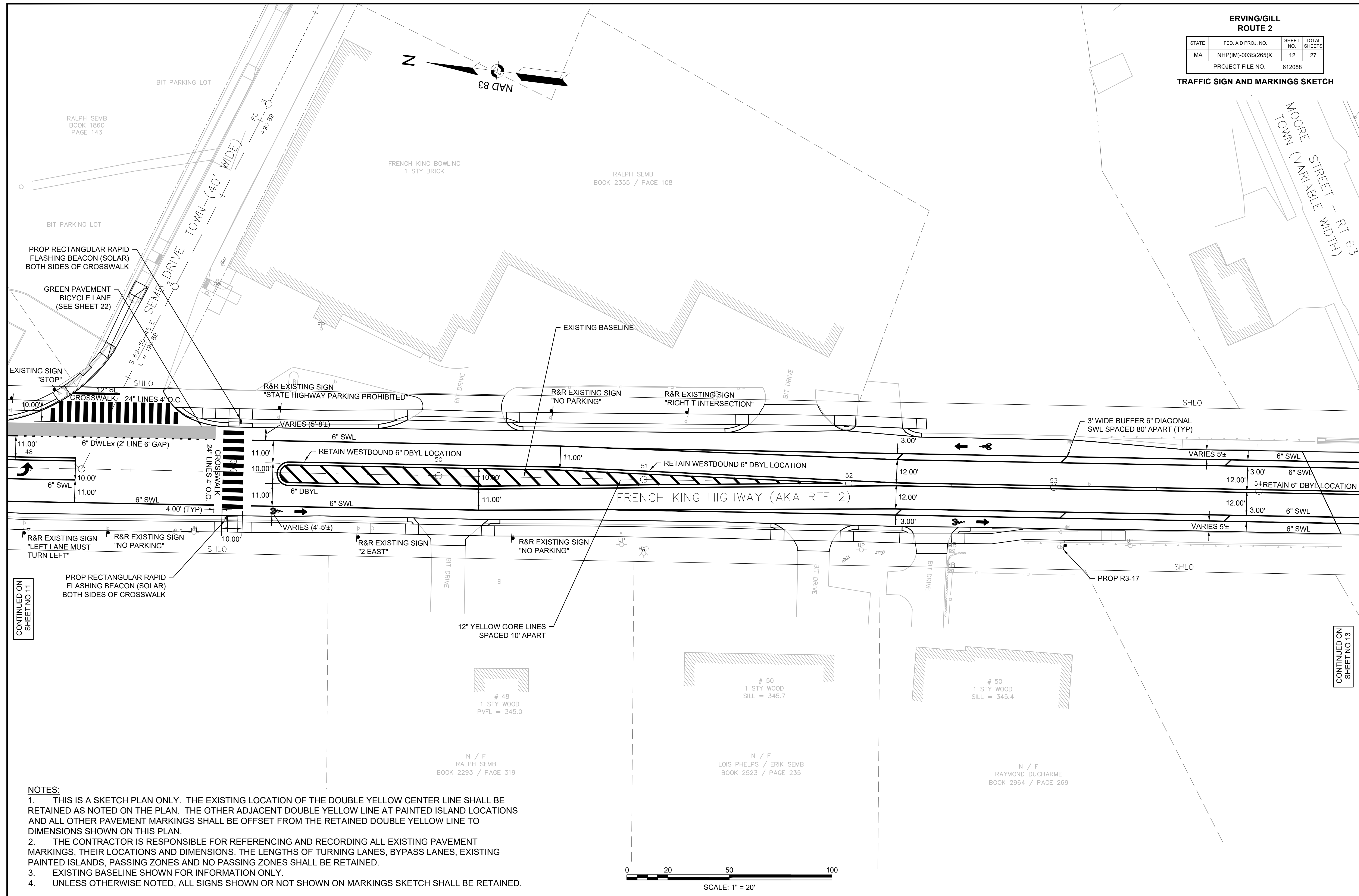

NOTES:

1. THIS IS A SKETCH PLAN ONLY. THE EXISTING LOCATION OF THE DOUBLE YELLOW CENTER LINE SHALL BE RETAINED AS NOTED ON THE PLAN. THE OTHER ADJACENT DOUBLE YELLOW LINE AT PAINTED ISLAND LOCATIONS AND ALL OTHER PAVEMENT MARKINGS SHALL BE OFFSET FROM THE RETAINED DOUBLE YELLOW LINE TO DIMENSIONS SHOWN ON THIS PLAN.
2. THE CONTRACTOR IS RESPONSIBLE FOR REFERENCING AND RECORDING ALL EXISTING PAVEMENT MARKINGS, THEIR LOCATIONS AND DIMENSIONS. THE LENGTHS OF TURNING LANES, BYPASS LANES, EXISTING PAINTED ISLANDS, PASSING ZONES AND NO PASSING ZONES SHALL BE RETAINED.
3. EXISTING BASELINE SHOWN FOR INFORMATION ONLY.
4. UNLESS OTHERWISE NOTED, ALL SIGNS SHOWN OR NOT SHOWN ON MARKINGS SKETCH SHALL BE RETAINED.

CONTINUED ON SHEET NO 11

CONTINUED ON SHEET NO 13

**ERVING/GILL
ROUTE 2**

STATE	FED. AID PROJ. NO.	SHEET NO.	TOTAL SHEETS
MA	NHP(IM)-003S(265)X	13	27
PROJECT FILE NO.		612088	

TRAFFIC SIGN AND MARKINGS SKETCH

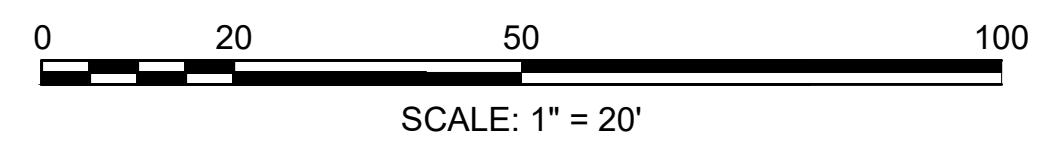
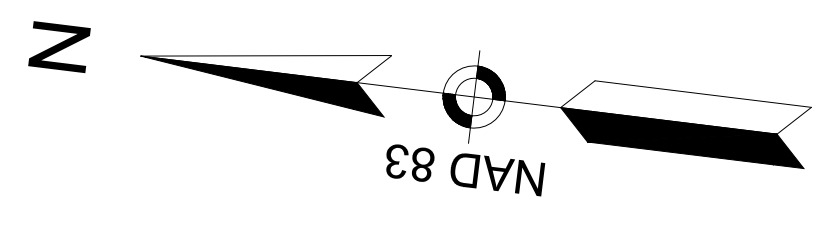
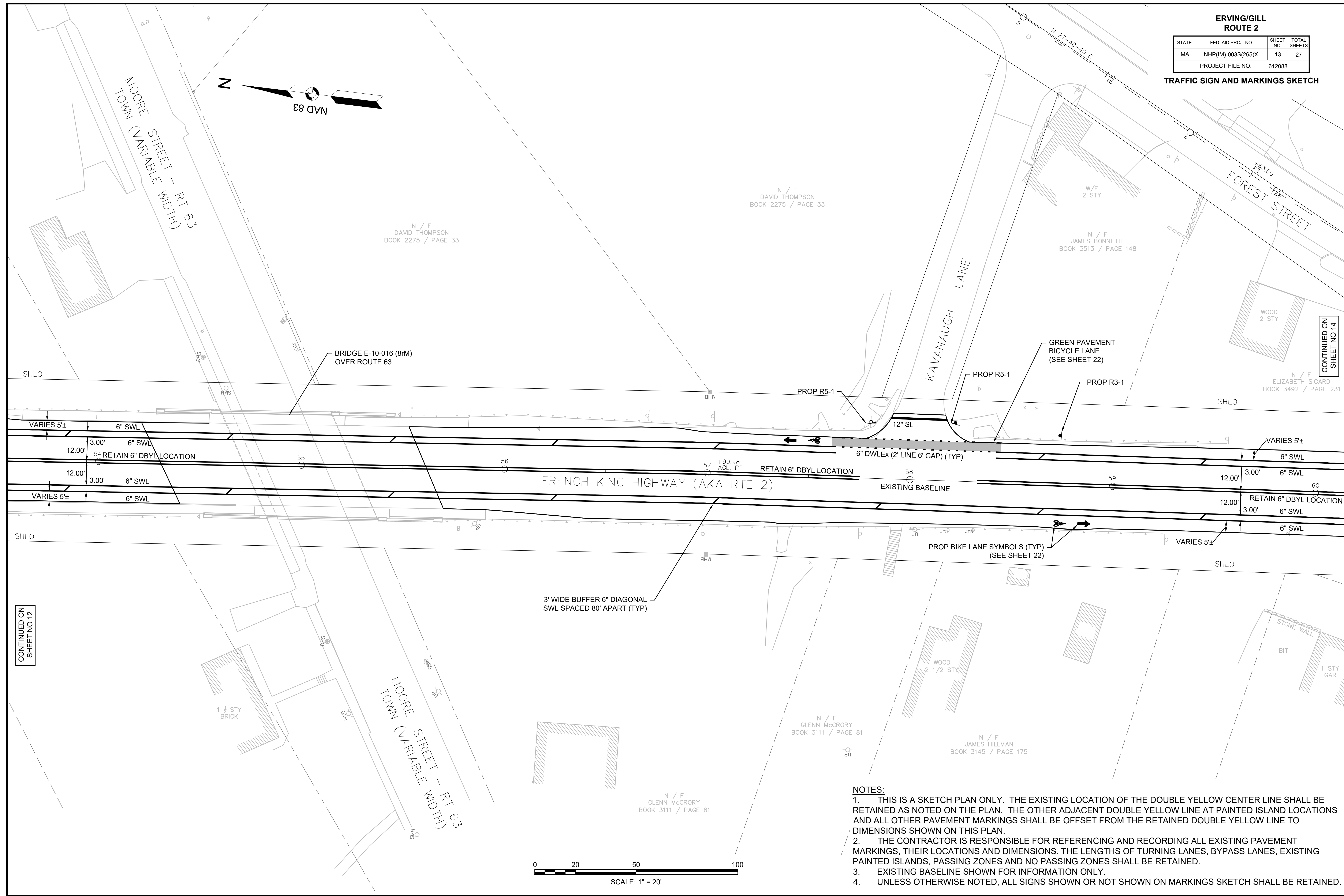

NOTES:

1. THIS IS A SKETCH PLAN ONLY. THE EXISTING LOCATION OF THE DOUBLE YELLOW CENTER LINE SHALL BE RETAINED AS NOTED ON THE PLAN. THE OTHER ADJACENT DOUBLE YELLOW LINE AT PAINTED ISLAND LOCATIONS AND ALL OTHER PAVEMENT MARKINGS SHALL BE OFFSET FROM THE RETAINED DOUBLE YELLOW LINE TO DIMENSIONS SHOWN ON THIS PLAN.
2. THE CONTRACTOR IS RESPONSIBLE FOR REFERENCING AND RECORDING ALL EXISTING PAVEMENT MARKINGS, THEIR LOCATIONS AND DIMENSIONS. THE LENGTHS OF TURNING LANES, BYPASS LANES, EXISTING PAINTED ISLANDS, PASSING ZONES AND NO PASSING ZONES SHALL BE RETAINED.
3. EXISTING BASELINE SHOWN FOR INFORMATION ONLY.
4. UNLESS OTHERWISE NOTED, ALL SIGNS SHOWN OR NOT SHOWN ON MARKINGS SKETCH SHALL BE RETAINED.

CONTINUED ON
SHEET NO 12

CONTINUED ON
SHEET NO 14

ERVING/GILL
ROUTE 2

STATE	FED. AID PROJ. NO.	SHEET NO.	TOTAL SHEETS
MA	NHP(IM)-003S(265)X	14	27
PROJECT FILE NO.		612088	

TRAFFIC SIGN AND MARKINGS SKETCH

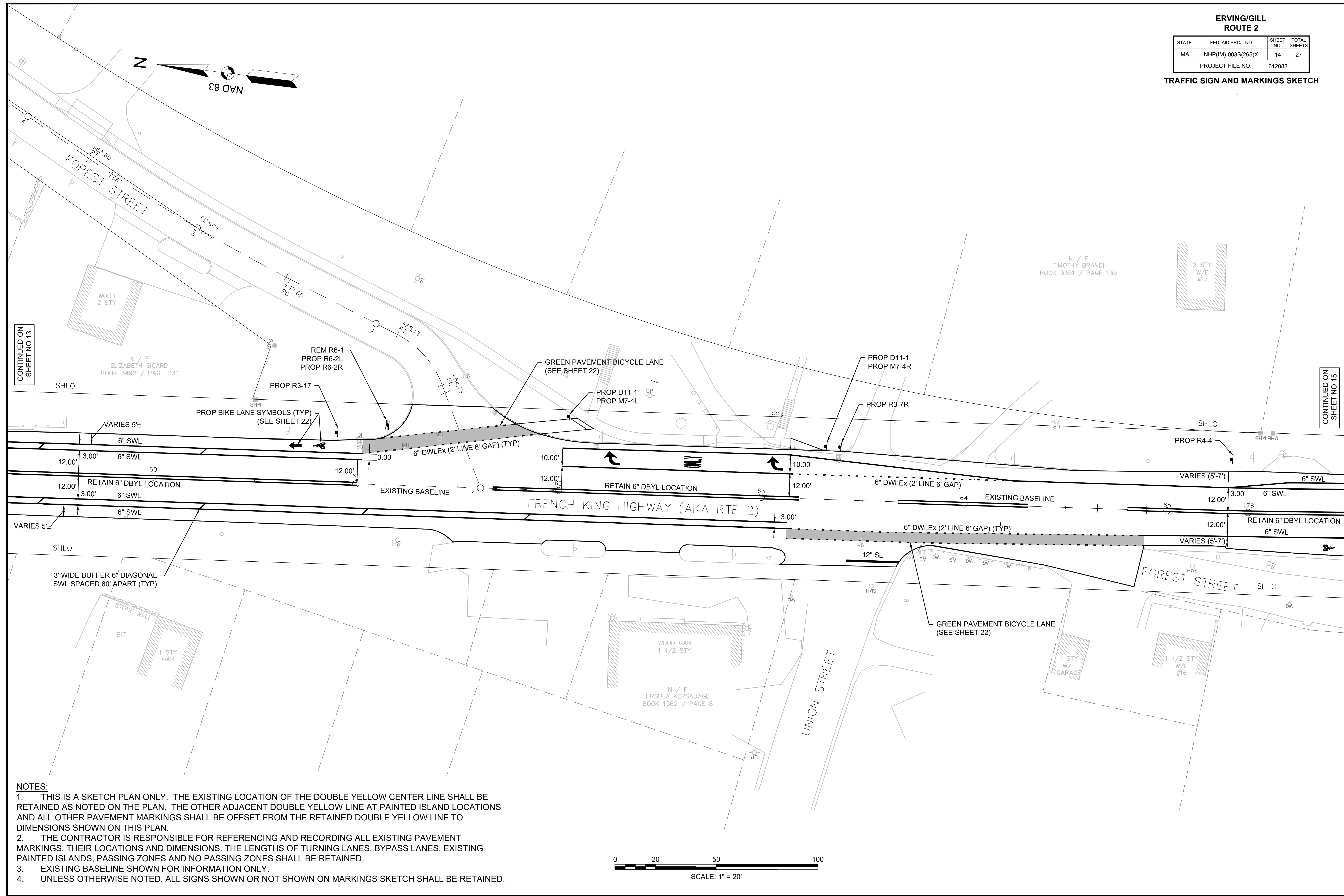

CONTINUED ON
SHEET NO 13

CONTINUED ON
SHEET NO 15

- NOTES:
- THIS IS A SKETCH PLAN ONLY. THE EXISTING LOCATION OF THE DOUBLE YELLOW CENTER LINE SHALL BE RETAINED AS NOTED ON THE PLAN. THE OTHER ADJACENT DOUBLE YELLOW LINE AT PAINTED ISLAND LOCATIONS AND ALL OTHER PAVEMENT MARKINGS SHALL BE OFFSET FROM THE RETAINED DOUBLE YELLOW LINE TO DIMENSIONS SHOWN ON THIS PLAN.
 - THE CONTRACTOR IS RESPONSIBLE FOR REFERENCING AND RECORDING ALL EXISTING PAVEMENT MARKINGS, THEIR LOCATIONS AND DIMENSIONS. THE LENGTHS OF TURNING LANES, BYPASS LANES, EXISTING PAINTED ISLANDS, PASSING ZONES AND NO PASSING ZONES SHALL BE RETAINED.
 - EXISTING BASELINE SHOWN FOR INFORMATION ONLY.
 - UNLESS OTHERWISE NOTED, ALL SIGNS SHOWN OR NOT SHOWN ON MARKINGS SKETCH SHALL BE RETAINED.

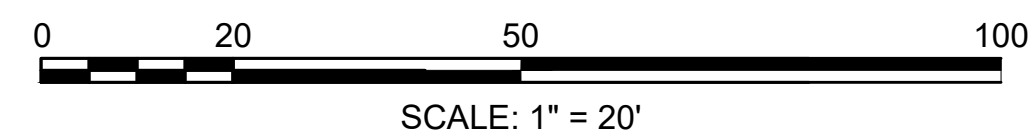

ERVING/GILL
ROUTE 2

STATE	FED. AID PROJ. NO.	SHEET NO.	TOTAL SHEETS
MA	NHP(IM)-003S(265)X	15	27
PROJECT FILE NO.		612088	

TRAFFIC SIGN AND MARKINGS SKETCH

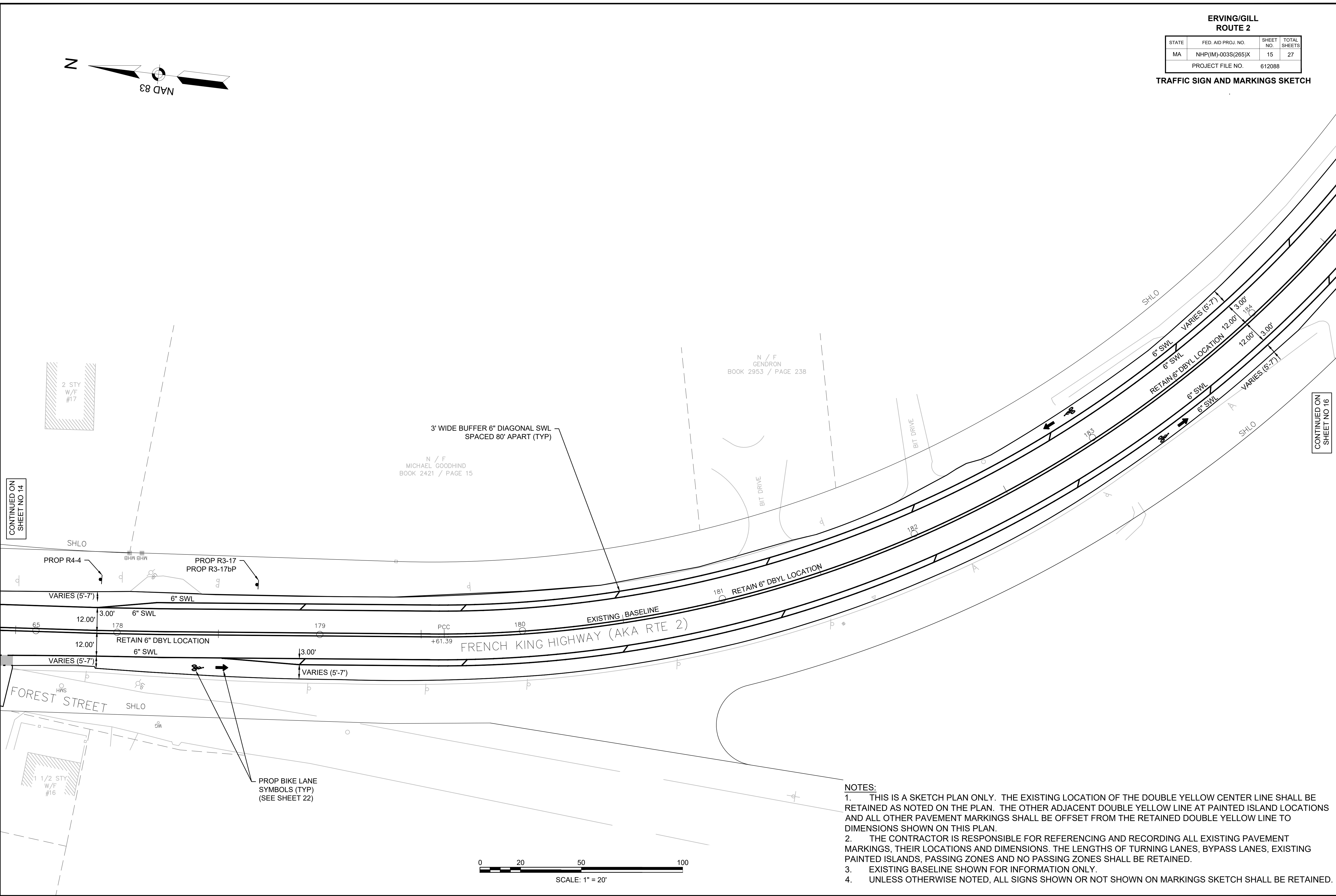
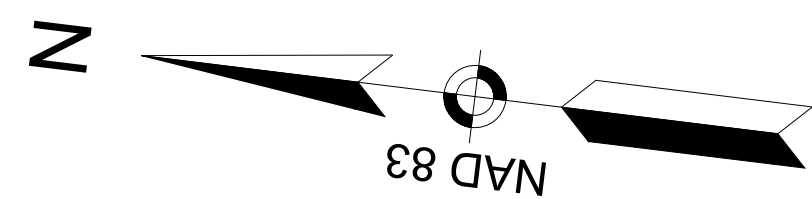

CONTINUED ON SHEET NO 14

CONTINUED ON SHEET NO 16

3' WIDE BUFFER 6" DIAGONAL SWL SPACED 80' APART (TYP)

N / F
MICHAEL GOODHIND
BOOK 2421 / PAGE 15

N / F
GENDRON
BOOK 2953 / PAGE 238

NOTES:

1. THIS IS A SKETCH PLAN ONLY. THE EXISTING LOCATION OF THE DOUBLE YELLOW CENTER LINE SHALL BE RETAINED AS NOTED ON THE PLAN. THE OTHER ADJACENT DOUBLE YELLOW LINE AT PAINTED ISLAND LOCATIONS AND ALL OTHER PAVEMENT MARKINGS SHALL BE OFFSET FROM THE RETAINED DOUBLE YELLOW LINE TO DIMENSIONS SHOWN ON THIS PLAN.
2. THE CONTRACTOR IS RESPONSIBLE FOR REFERENCING AND RECORDING ALL EXISTING PAVEMENT MARKINGS, THEIR LOCATIONS AND DIMENSIONS. THE LENGTHS OF TURNING LANES, BYPASS LANES, EXISTING PAINTED ISLANDS, PASSING ZONES AND NO PASSING ZONES SHALL BE RETAINED.
3. EXISTING BASELINE SHOWN FOR INFORMATION ONLY.
4. UNLESS OTHERWISE NOTED, ALL SIGNS SHOWN OR NOT SHOWN ON MARKINGS SKETCH SHALL BE RETAINED.

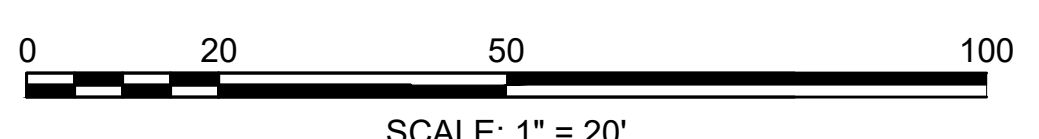

ERVING/GILL
ROUTE 2

STATE	FED. AID PROJ. NO.	SHEET NO.	TOTAL SHEETS
MA	NHP(IM)-003S(265)X	16	27
PROJECT FILE NO.		612088	

TRAFFIC SIGN AND MARKINGS SKETCH

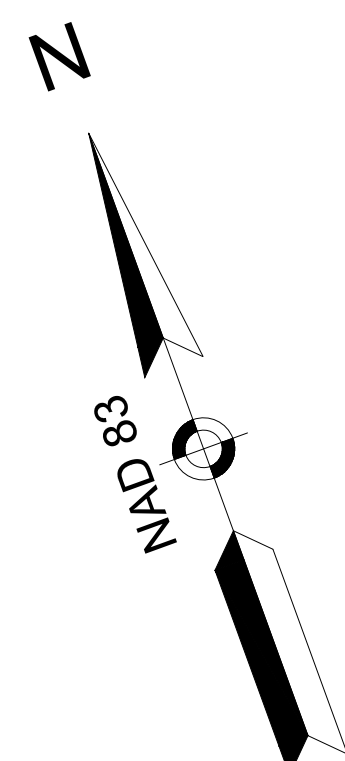

POMEROY
BOOK 2953 / PAGE 236

N / F
POMEROY
BOOK 2956 / PAGE 175

N / F
DORSEY
BOOK 1484 / PAGE 116

CONTINUED ON
SHEET NO 15

CONTINUED ON
SHEET NO 17

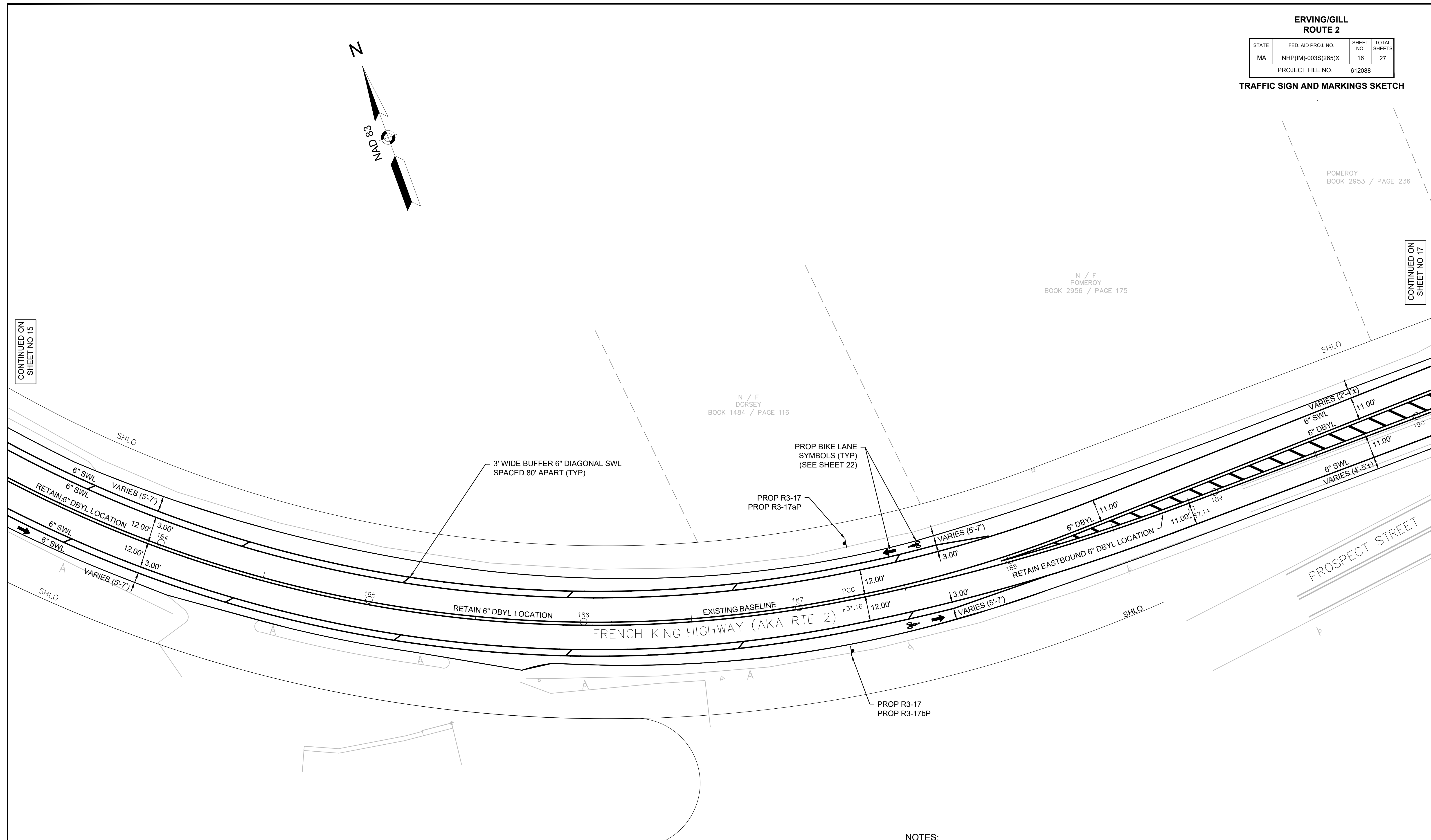

PROSPECT STREET

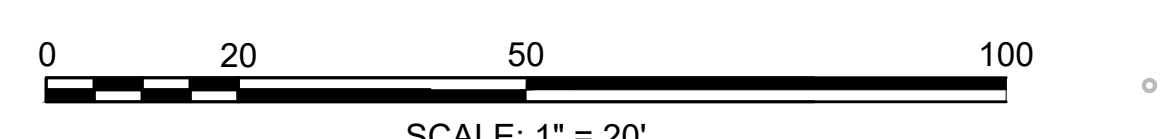

- NOTES:
1. THIS IS A SKETCH PLAN ONLY. THE EXISTING LOCATION OF THE DOUBLE YELLOW CENTER LINE SHALL BE RETAINED AS NOTED ON THE PLAN. THE OTHER ADJACENT DOUBLE YELLOW LINE AT PAINTED ISLAND LOCATIONS AND ALL OTHER PAVEMENT MARKINGS SHALL BE OFFSET FROM THE RETAINED DOUBLE YELLOW LINE TO DIMENSIONS SHOWN ON THIS PLAN.
 2. THE CONTRACTOR IS RESPONSIBLE FOR REFERENCING AND RECORDING ALL EXISTING PAVEMENT MARKINGS, THEIR LOCATIONS AND DIMENSIONS. THE LENGTHS OF TURNING LANES, BYPASS LANES, EXISTING PAINTED ISLANDS, PASSING ZONES AND NO PASSING ZONES SHALL BE RETAINED.
 3. EXISTING BASELINE SHOWN FOR INFORMATION ONLY.
 4. UNLESS OTHERWISE NOTED, ALL SIGNS SHOWN OR NOT SHOWN ON MARKINGS SKETCH SHALL BE RETAINED.

ERVING/GILL
ROUTE 2

STATE	FED. AID PROJ. NO.	SHEET NO.	TOTAL SHEETS
MA	NHP(IM)-003S(265)X	17	27
PROJECT FILE NO.		612088	

TRAFFIC SIGN AND MARKINGS SKETCH

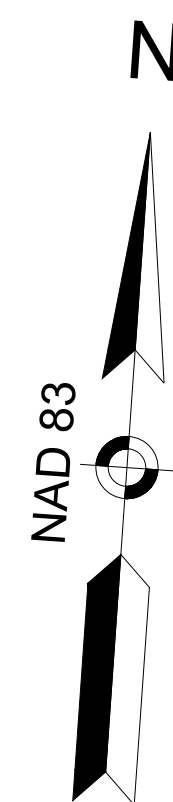

POMEROY
BOOK 2953 / PAGE 236

N / F
GENDRON
BOOK 1618 / PAGE 326

CONTINUED ON
SHEET NO 16

CONTINUED ON
SHEET NO 18

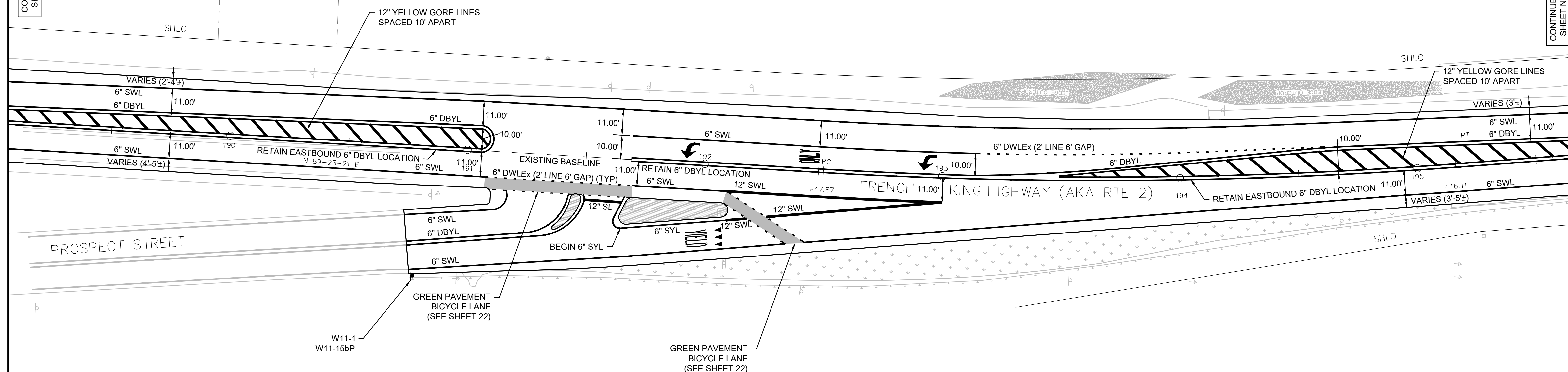

NOTES:

1. THIS IS A SKETCH PLAN ONLY. THE EXISTING LOCATION OF THE DOUBLE YELLOW CENTER LINE SHALL BE RETAINED AS NOTED ON THE PLAN. THE OTHER ADJACENT DOUBLE YELLOW LINE AT PAINTED ISLAND LOCATIONS AND ALL OTHER PAVEMENT MARKINGS SHALL BE OFFSET FROM THE RETAINED DOUBLE YELLOW LINE TO DIMENSIONS SHOWN ON THIS PLAN.
2. THE CONTRACTOR IS RESPONSIBLE FOR REFERENCING AND RECORDING ALL EXISTING PAVEMENT MARKINGS, THEIR LOCATIONS AND DIMENSIONS. THE LENGTHS OF TURNING LANES, BYPASS LANES, EXISTING PAINTED ISLANDS, PASSING ZONES AND NO PASSING ZONES SHALL BE RETAINED.
3. EXISTING BASELINE SHOWN FOR INFORMATION ONLY.
4. UNLESS OTHERWISE NOTED, ALL SIGNS SHOWN OR NOT SHOWN ON MARKINGS SKETCH SHALL BE RETAINED.

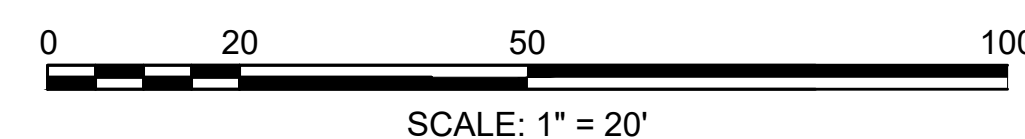

ERVING/GILL
ROUTE 2

STATE	FED. AID PROJ. NO.	SHEET NO.	TOTAL SHEETS
MA	NHP(IM)-003S(265)X	18	27
PROJECT FILE NO.		612088	

TRAFFIC SIGN AND MARKINGS SKETCH

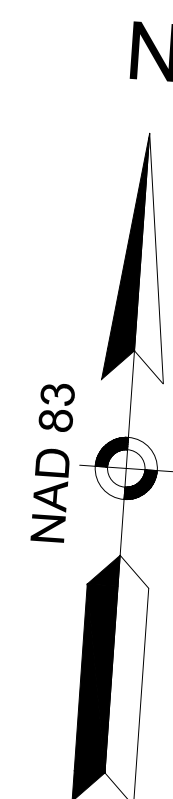

CONTINUED ON
SHEET NO. 17

CONTINUED ON
SHEET NO. 19

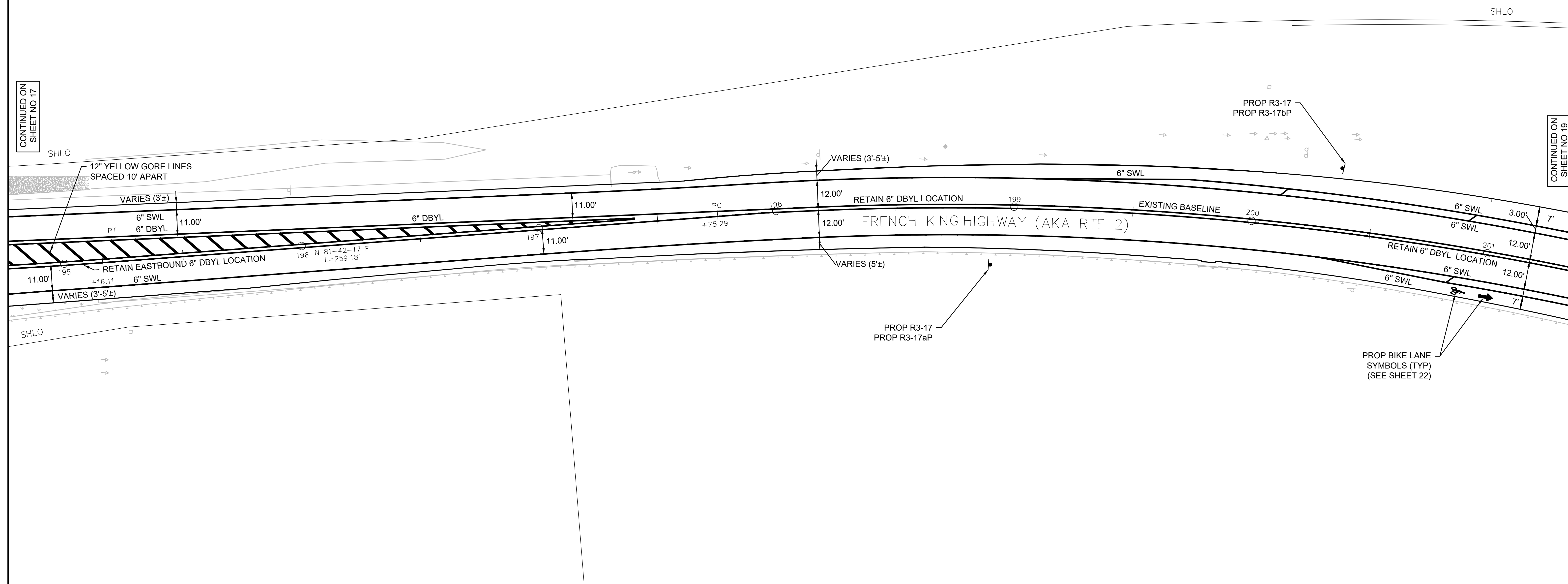

NOTES:

1. THIS IS A SKETCH PLAN ONLY. THE EXISTING LOCATION OF THE DOUBLE YELLOW CENTER LINE SHALL BE RETAINED AS NOTED ON THE PLAN. THE OTHER ADJACENT DOUBLE YELLOW LINE AT PAINTED ISLAND LOCATIONS AND ALL OTHER PAVEMENT MARKINGS SHALL BE OFFSET FROM THE RETAINED DOUBLE YELLOW LINE TO DIMENSIONS SHOWN ON THIS PLAN.
2. THE CONTRACTOR IS RESPONSIBLE FOR REFERENCING AND RECORDING ALL EXISTING PAVEMENT MARKINGS, THEIR LOCATIONS AND DIMENSIONS. THE LENGTHS OF TURNING LANES, BYPASS LANES, EXISTING PAINTED ISLANDS, PASSING ZONES AND NO PASSING ZONES SHALL BE RETAINED.
3. EXISTING BASELINE SHOWN FOR INFORMATION ONLY.
4. UNLESS OTHERWISE NOTED, ALL SIGNS SHOWN OR NOT SHOWN ON MARKINGS SKETCH SHALL BE RETAINED.

ERVING/GILL
ROUTE 2

STATE	FED. AID PROJ. NO.	SHEET NO.	TOTAL SHEETS
MA	NHP(IM)-003S(265)X	19	27
PROJECT FILE NO.		612088	

TRAFFIC SIGN AND MARKINGS SKETCH

SHLO

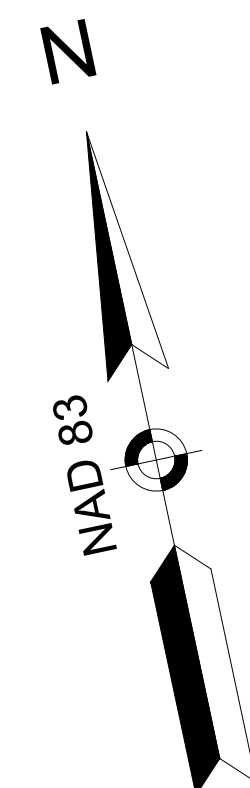

CONTINUED ON
SHEET NO. 18

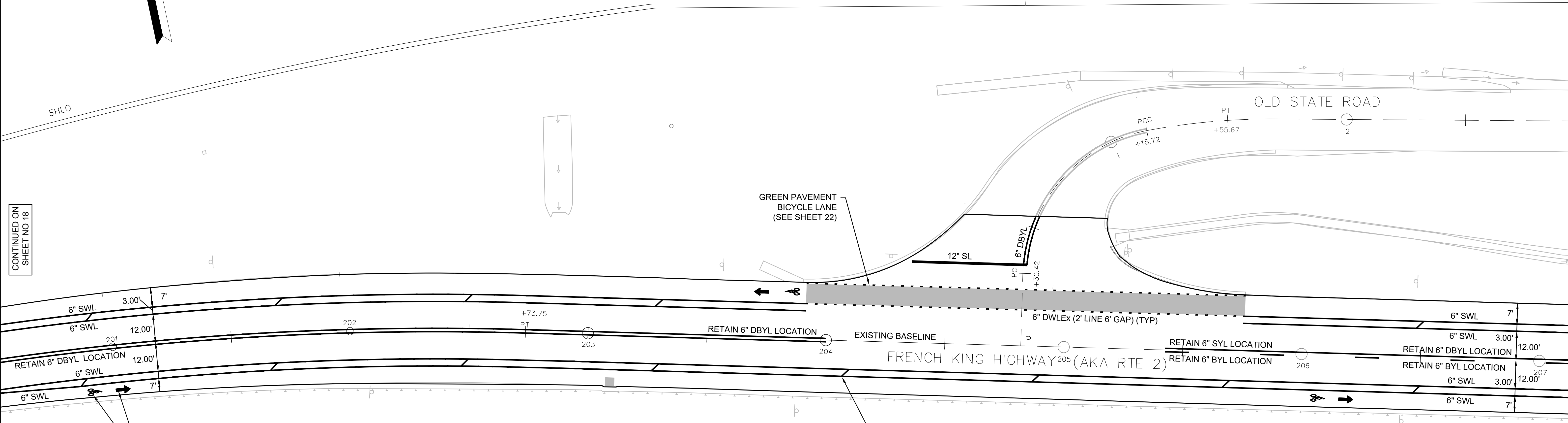

PROP BIKE LANE
SYMBOLS (TYP)
(SEE SHEET 22)

3' WIDE BUFFER 6" DIAGONAL
SWL SPACED 80' APART (TYP)

CONTINUED ON
SHEET NO. 20

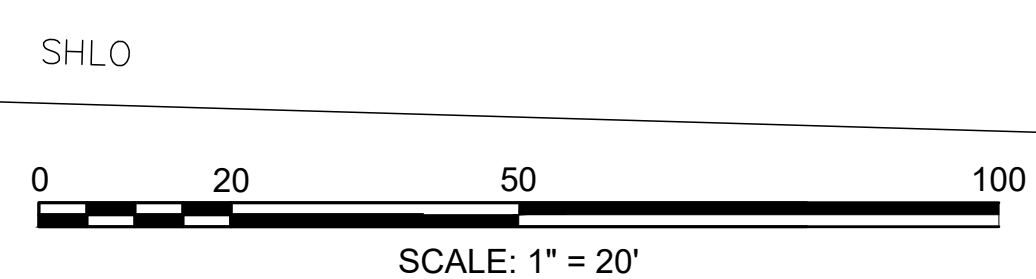

NOTES:

1. THIS IS A SKETCH PLAN ONLY. THE EXISTING LOCATION OF THE DOUBLE YELLOW CENTER LINE SHALL BE RETAINED AS NOTED ON THE PLAN. THE OTHER ADJACENT DOUBLE YELLOW LINE AT PAINTED ISLAND LOCATIONS AND ALL OTHER PAVEMENT MARKINGS SHALL BE OFFSET FROM THE RETAINED DOUBLE YELLOW LINE TO DIMENSIONS SHOWN ON THIS PLAN.
2. THE CONTRACTOR IS RESPONSIBLE FOR REFERENCING AND RECORDING ALL EXISTING PAVEMENT MARKINGS, THEIR LOCATIONS AND DIMENSIONS. THE LENGTHS OF TURNING LANES, BYPASS LANES, EXISTING PAINTED ISLANDS, PASSING ZONES AND NO PASSING ZONES SHALL BE RETAINED.
3. EXISTING BASELINE SHOWN FOR INFORMATION ONLY.
4. UNLESS OTHERWISE NOTED, ALL SIGNS SHOWN OR NOT SHOWN ON MARKINGS SKETCH SHALL BE RETAINED.

ERVING/GILL
ROUTE 2

STATE	FED. AID PROJ. NO.	SHEET NO.	TOTAL SHEETS
MA	NHP(IM)-003S(265)X	20	27
PROJECT FILE NO.		612088	

TRAFFIC SIGN AND MARKINGS SKETCH

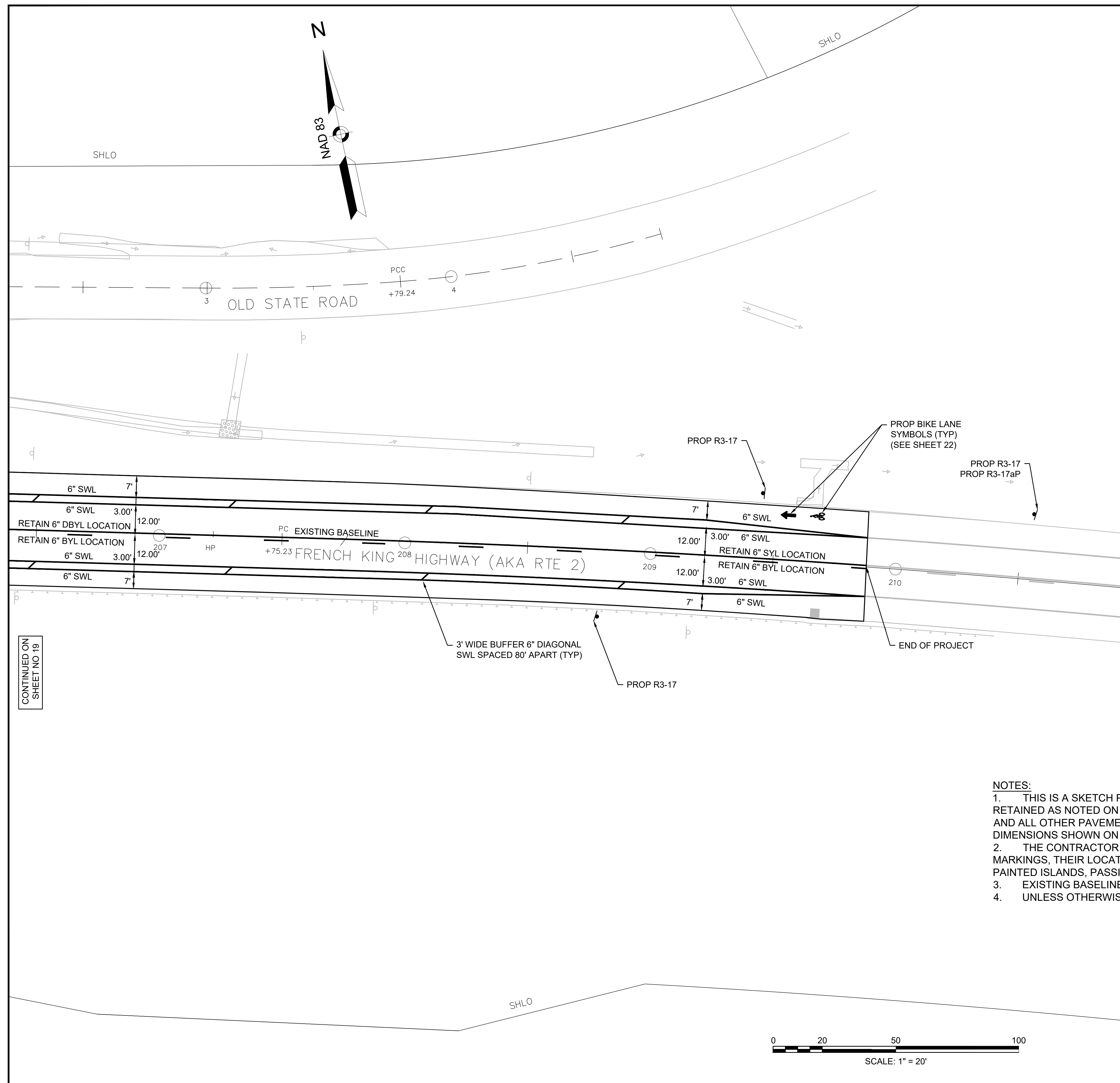

CONTINUED ON
SHEET NO 19

- NOTES:**
1. THIS IS A SKETCH PLAN ONLY. THE EXISTING LOCATION OF THE DOUBLE YELLOW CENTER LINE SHALL BE RETAINED AS NOTED ON THE PLAN. THE OTHER ADJACENT DOUBLE YELLOW LINE AT PAINTED ISLAND LOCATIONS AND ALL OTHER PAVEMENT MARKINGS SHALL BE OFFSET FROM THE RETAINED DOUBLE YELLOW LINE TO DIMENSIONS SHOWN ON THIS PLAN.
 2. THE CONTRACTOR IS RESPONSIBLE FOR REFERENCING AND RECORDING ALL EXISTING PAVEMENT MARKINGS, THEIR LOCATIONS AND DIMENSIONS. THE LENGTHS OF TURNING LANES, BYPASS LANES, EXISTING PAINTED ISLANDS, PASSING ZONES AND NO PASSING ZONES SHALL BE RETAINED.
 3. EXISTING BASELINE SHOWN FOR INFORMATION ONLY.
 4. UNLESS OTHERWISE NOTED, ALL SIGNS SHOWN OR NOT SHOWN ON MARKINGS SKETCH SHALL BE RETAINED.

